

GN 350.5

Levelling sets

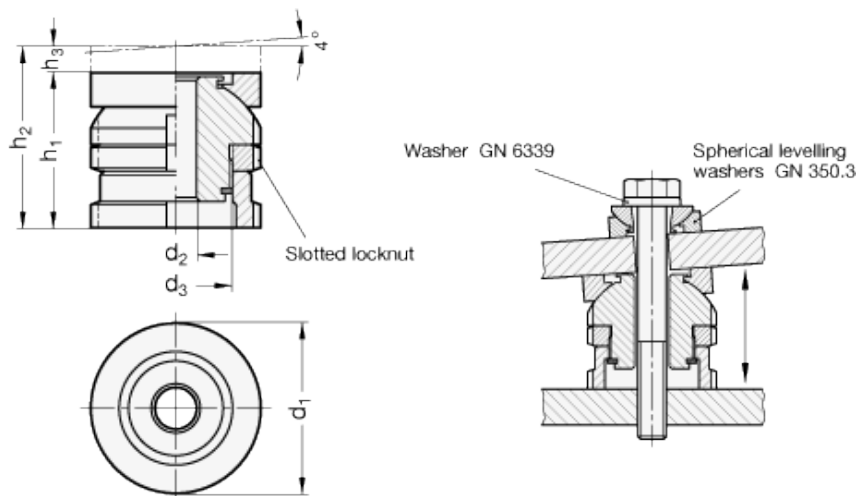

technical informations

Material

Zinc-plated steel 1.7225 (42CrMo 4 V) ST, blue passivated.

F_1 : max. total load.

F_2 : max. load after deduction of the max. preload for screws 8.8, $\mu = 0.125$.

Accessories on request

C-Spanner DIN 1810 (code no. see table).

Features and applications

Levelling sets GN 350.5 are used for levelling, adjusting and linking operations. The spherical washer allows precise installation of two non parallel planes at a required gradient up to $\approx 4^\circ$.

They comprise a threaded upper sleeve and a female threaded lower sleeve. The fine thread allows a stepless and precise setting and locking using the C-Spanner DIN 1810. A locking ring serves as a height limiter for the max. height.

Description	d ₁	d ₂	h ₁	d ₃	h ₂	h ₃	for screw	F ₁	F ₂	C-Spanner	g
GN 350.5-25-5.5-27-ST	25	5.5	27	M15x1	31	4	M5	40	33.4	DIN 1810-A25-28	90
GN 350.5-25-5.5-40-ST	25	5.5	40	M15x1	50	10	M5	40	33.4	DIN 1810-A25-28	95
GN 350.5-25-6.6-27-ST	25	6.6	27	M15x1	31	4	M6	40	30.7	DIN 1810-A25-28	80
GN 350.5-25-6.6-40-ST	25	6.6	40	M15x1	50	10	M6	40	30.7	DIN 1810-A25-28	85
GN 350.5-32-6.6-32-ST	32	6.6	32	M20x1	37	5	M6	65	55.7	DIN 1810-A30-32	140
GN 350.5-32-6.6-49-ST	32	6.6	49	M20x1	63	14	M6	65	55.7	DIN 1810-A30-32	147
GN 350.5-32-9-32-ST	32	9	32	M20x1	37	5	M8	65	48	DIN 1810-A30-32	130
GN 350.5-32-9-49-ST	32	9	49	M20x1	63	14	M8	65	48	DIN 1810-A30-32	147
GN 350.5-32-11-32-ST	32	11	32	M20x1	37	5	M10	65	37.9	DIN 1810-A30-32	120
GN 350.5-32-11-49-ST	32	11	49	M20x1	63	14	M10	65	37.9	DIN 1810-A30-32	127
GN 350.5-45-11-41-ST	45	11	41	M30x1.5	48	7	M10	120	92.9	DIN 1810-A45-50	360
GN 350.5-45-11-61-ST	45	11	61	M30x1.5	79	18	M10	120	92.9	DIN 1810-A45-50	399
GN 350.5-45-13.5-41-ST	45	13.5	41	M30x1.5	48	7	M12	120	80.4	DIN 1810-A45-50	350
GN 350.5-45-13.5-61-ST	45	13.5	61	M30x1.5	79	18	M12	120	80.4	DIN 1810-A45-50	390
GN 350.5-45-17.5-41-ST	45	17.5	41	M30x1.5	48	7	M16	120	45.5	DIN 1810-A45-50	340
GN 350.5-45-17.5-61-ST	45	17.5	61	M30x1.5	79	18	M16	120	45.5	DIN 1810-A45-50	380
GN 350.5-58-17.5-53-ST	58	17.5	53	M40x1.5	62	9	M16	210	136	DIN 1810-A58-62	780
GN 350.5-58-17.5-79-ST	58	17.5	79	M40x1.5	102	9	M16	210	136	DIN 1810-A58-62	889
GN 350.5-58-22-53-ST	58	22	53	M40x1.5	62	9	M20	210	90	DIN 1810-A58-62	770
GN 350.5-58-22-79-ST	58	22	79	M40x1.5	102	23	M20	210	90	DIN 1810-A58-62	840
GN 350.5-58-26-53-ST	58	26	53	M40x1.5	62	9	M24	210	37	DIN 1810-A58-62	760
GN 350.5-58-26-79-ST	28	26	79	M40x1.5	102	23	M24	210	37	DIN 1810-A58-62	830
GN 350.5-70-22-61-ST	70	22	61	M50x1.5	71	10	M20	330	210	DIN 1810-A68-75	1300
GN 350.5-70-22-94-ST	70	22	94	M50x1.5	123	29	M20	330	210	DIN 1810-A68-75	1418
GN 350.5-70-26-61-ST	70	26	61	M50x1.5	71	10	M24	330	157	DIN 1810-A68-75	1200
GN 350.5-70-26-94-ST	70	26	94	M50x1.5	123	29	M24	330	157	DIN 1810-A68-75	1300
GN 350.5-70-33-61-ST	70	33	61	M50x1.5	71	10	M30	330	53	DIN 1810-A68-75	1100
GN 350.5-70-33-94-ST	70	33	94	M50x1.5	123	29	M30	330	53	DIN 1810-A68-75	1200
GN 350.5-80-26-67-ST	80	26	105	M60x2	79	12	M24	495	322	DIN 1810-A80-90	1650
GN 350.5-80-26-105-ST	80	26	105	M60x2	144	39	M24	495	322	DIN 1810-A80-90	1800
GN 350.5-80-33-67-ST	80	33	67	M60x2	79	12	M30	495	218	DIN 1810-A80-90	1550
GN 350.5-80-33-105-ST	80	33	105	M60x2	144	39	M30	495	218	DIN 1810-A80-90	1911
GN 350.5-80-39-67-ST	80	39	67	M60x2	79	12	M36	495	101	DIN 1810-A80-90	1450
GN 350.5-80-39-105-ST	80	39	105	M60x2	144	39	M36	495	101	DIN 1810-A80-90	1490



STANDARD MACHINE ELEMENTS WORLDWIDE